

Trail Gear 4340 Chromoly Hub Gears, Inner and Outer (SKU# TAX-CH, TAX-CHG-10)
Instructions Also Include:

SKU# TAX-HDO Toyota Aisin Hub Outer Dial O-Ring

SKU# TAXP-HGAS Toyota / Suzuki Solid Axle Aisin/Asco Hub Gasket, Outer

SKU# TAXP-HGASI Toyota / Suzuki Solid Axle Aisin/Asco Hub Gasket, Inner

SKU# TAX-HG Longfield 4340 Chromoly Hub Gears

SKU# TAX-HUB Aisin Toyota Manual Locking Hubs '79-85 4Runner, Hilux Pickup

Installation Instructions



TAX-HG

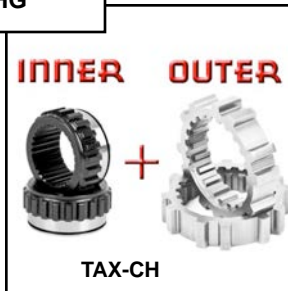

INNER OUTER

TAX-CH

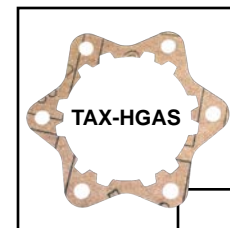

TAX-HGAS



TAX-HGASI



TAX-HDO

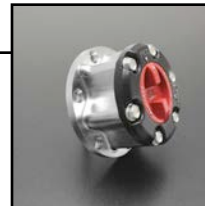

TAX-HUB

CAUTION: Safety glasses should be worn at all times when working with vehicles and related tools and equipment.



FOR ADDITIONAL COPIES OF THESE AND OTHER INSTRUCTIONS GO TO:

www.lowrangeoffroad.com and click on the "INSTRUCTIONS" tab.

Suggested Tools:

- Small Standard Screwdriver
- Pic Tool
- Snap Ring Pliers
- 10 mm socket and ratchet
- Inch-Pound Torque Wrench
- Foot-Pound Torque Wrench
- Multi-Purpose (or wheel bearing) Grease

Hub Assembly Parts Identification

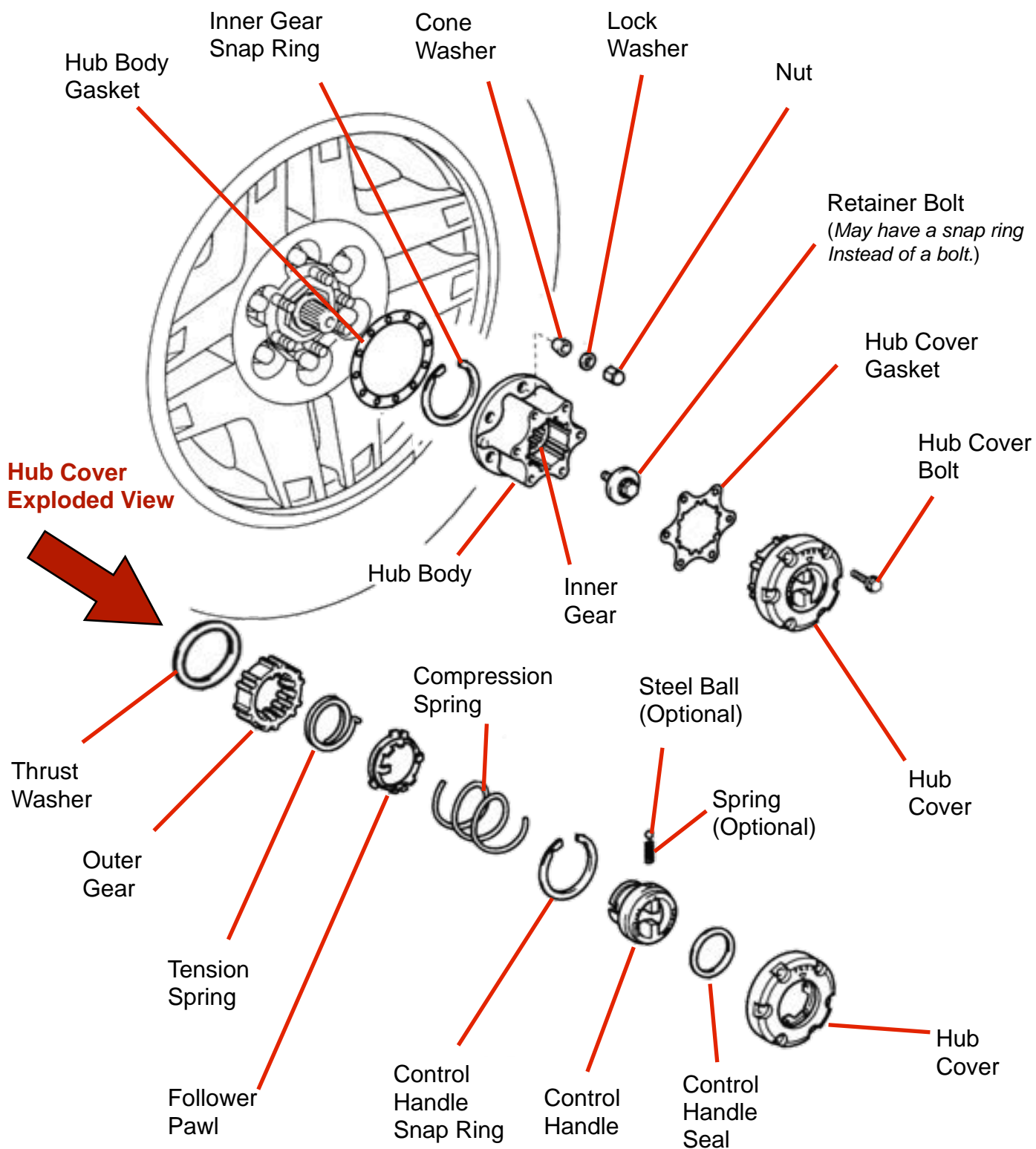

Disassembling the Hub



Background Information

These instructions begin with the hub off the vehicle.

Step 1

If not done already, remove the (6) hub cover bolts using a 10 mm socket. If the hub cover has been removed skip to Step 3.

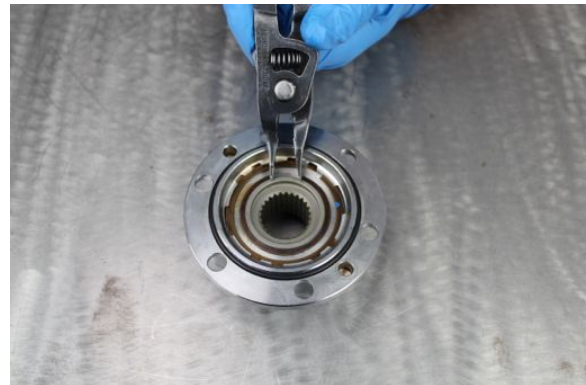

Step 2

Remove the hub cover.

Note: It is recommended that this gasket be replaced during reassembly.

Step 3

Turn the hub body over and remove the Internal gear snap ring using snap ring pliers.





Step 3 (continued)

Snap Ring removed.



Step 4

Lift up the hub and remove the inner gear from the bottom.



Step 5

Remove the thrust washer from the hub body and set the hub body and thrust washer aside.



Step 6

Remove the hub cover gasket from the hub cover.





Step 7

Position the control handle in the lock position.



Step 8

Unlock the outer gear and follower pawl from the hub cover by compress the spring . . . ,



Step 8 Continued

. . . rotating the gear clockwise and unlock it.



Step 8 Continued

Separate the outer gear and spring from the hub cover.





Step 9

Remove the compression spring and set it aside.



Step 10

Remove the follower pawl and the tension spring from the outer gear. This is done by grasping the pawl tabs with two fingers, pulling the pawl and spring away from the outer gear and rotating the pawl and spring counter clockwise.



Step 11

This shows the pawl and tension spring removed from the outer gear.



Step 12

Using a small screwdriver, rotate the snap ring so that the end of the ring is positioned as shown in the next picture.



Step 12 Continued

Snap ring end is placed in front of access notch.

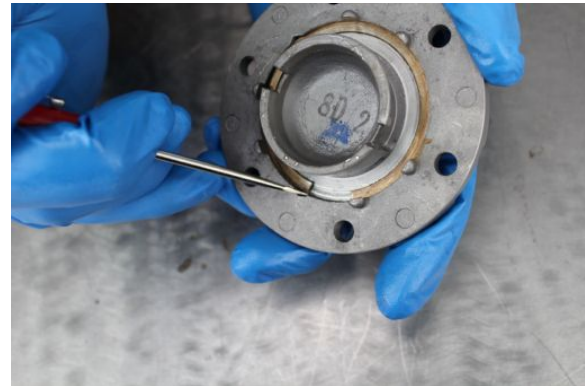

Step 13

Work a small sharp screwdriver through the access notch, under the snap ring and pry in and up on the snap ring.



Step 14

Work the screwdriver under the snap ring moving in a counter clockwise direction until the snap ring is free. Set the snap ring aside.



Step 15

Remove the control handle from the hub cover.



Step 16

Remove and inspect the seal. If the seal is cracked, brittle or damaged in any way it should be replaced.

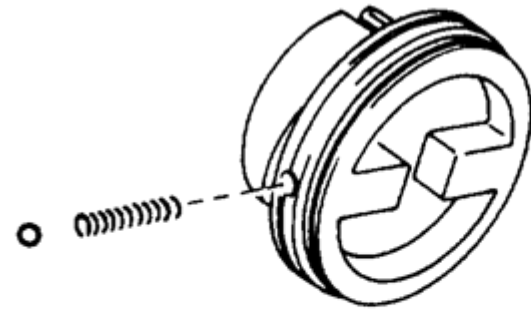

Step 17

Some hub control handles have a spring and a steel ball as shown in the illustration above. If it does, remove the ball and spring.



Step 18

Inspect the control handle for free movement by temporarily installing the handle in the cover with out the seal, spring or ball. Rotate the handle between the "Free" and "Lock" position to check that the handle moves smoothly and freely.



Step 19

Clean and inspect all parts. Replace any parts showing excessive wear or damage.



Reassembling the Hub

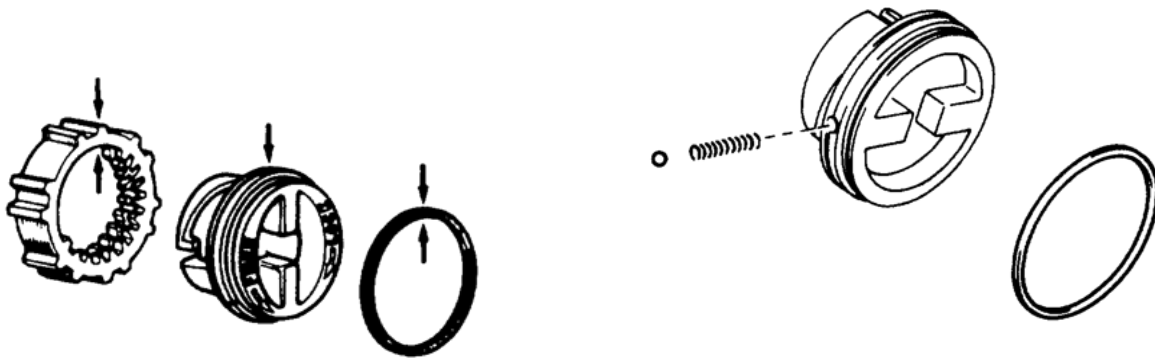

Tech Tip 19A

Before installation, apply wheel bearing grease to each of the sliding surfaces indicated by the arrows.

Step 20

Install the old spring and ball if removed earlier.



Step 21

Reinstall the seal or a new one if the old one was bad.

Note: Be sure it is not twisted and don't forget the grease.

Step 22

Insert the handle into the hub cover.

Note: Do not forget to apply grease to the sliding surfaces.



Step 23

Install the snap ring by starting it into the groove at one end and working it around as shown.



Tech Tip 23

Insure that the snap ring fits into the groove all the way around. Then set the cover aside.



Step 24

Install the follower pawl and tension spring in the new chromoly outer gear by inserting the straight end of the tension spring in the groove of the gear.



Step 25

The straight end of the spring should be aligned in the groove as shown, and positioned as shown in the next photograph.





Tech Tip 25A

This shows the straight end of the tension spring properly positioned in the outer gear groove.



Tech Tip 25B

This shows the bent end of the tension spring properly positioned in the follower pawl and the pawl properly positioned in the outer gear.

Note: Notice the tab of the follower pawl properly positioned between the two teeth of the outer gear.



Step 26

Install the compression spring onto the the follower pawl.

Note: Be sure the white painted end is oriented away from the pawl.

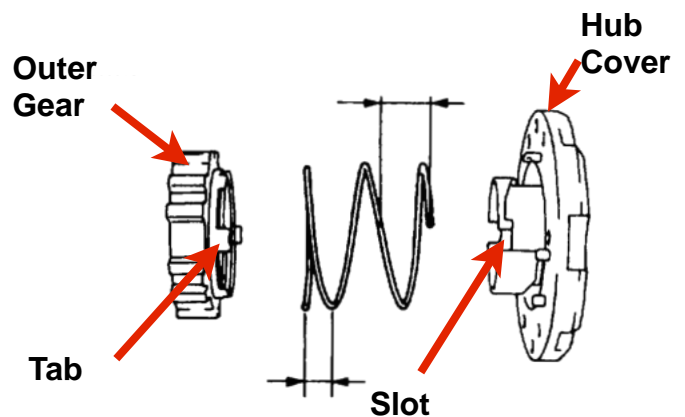

Tech Tip 26

If there is no paint on the compression spring indicating spring orientation, the spring should be oriented with the smaller spring end toward the outer gear (or in other words away from the hub cover).





Step 27

Position the cover against the spring, orient the tab of the pawl with the slot in the cover and push the two parts together, compressing the spring.



Step 28

Once the pawl and the cover are engaged, twist the outer gear counter-clockwise, locking the two parts together.



Step 28 Continued

This shows the pawl and the hub cover properly locked together.



Step 29

Move the control handle back and forth between the "Free" and "Lock" position. It should move freely. The outer gear should move **AWAY** from the hub cover when being moved to the "lock" position and **TOWARD** the hub cover when moved to the "Free" position. If it does not work properly, repeat steps _____ through _____ until the outer gear moves properly.





Step 30

Apply a small amount of grease to both sides of the thrust washer and install it in the hub body as shown.



Step 31

Apply a coating of bearing grease to the outer surfaces of the new chromoly inner gear and install it inside the hub body against the thrust washer as shown.

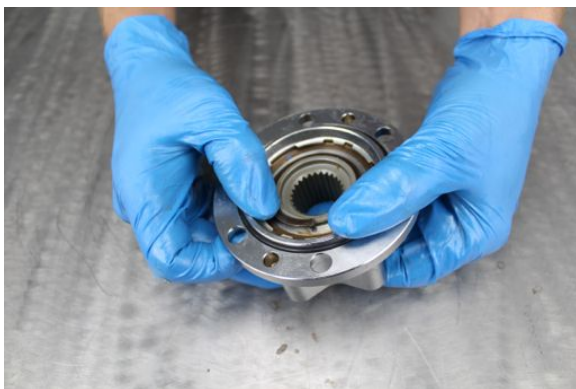

Step 32

Turn the hub over and replace the snap ring by starting it into the groove at one end and working it into the groove all the way around.



Step 33

Insure the snap ring is properly seated all the way around the groove.



Notice:

If the hub is NOT to be installed on the vehicle at this time, skip to Step 36. If the hub is to be installed on the vehicle now continue to the next step.

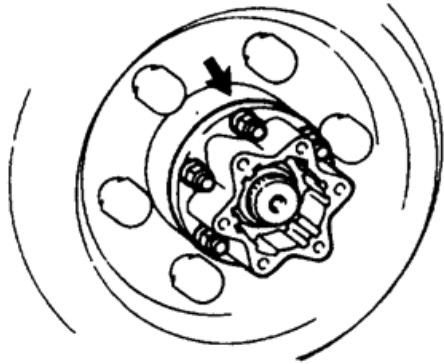

Step 34

If the hub is to be installed on the vehicle at this time, install a new gasket in position on the axle hub and install the hub body on the studs with the 6 cone washers, lock washers and nuts. Torque the nuts in an increasingly tighter criss-cross pattern until 23 ft. lbs. is reached.

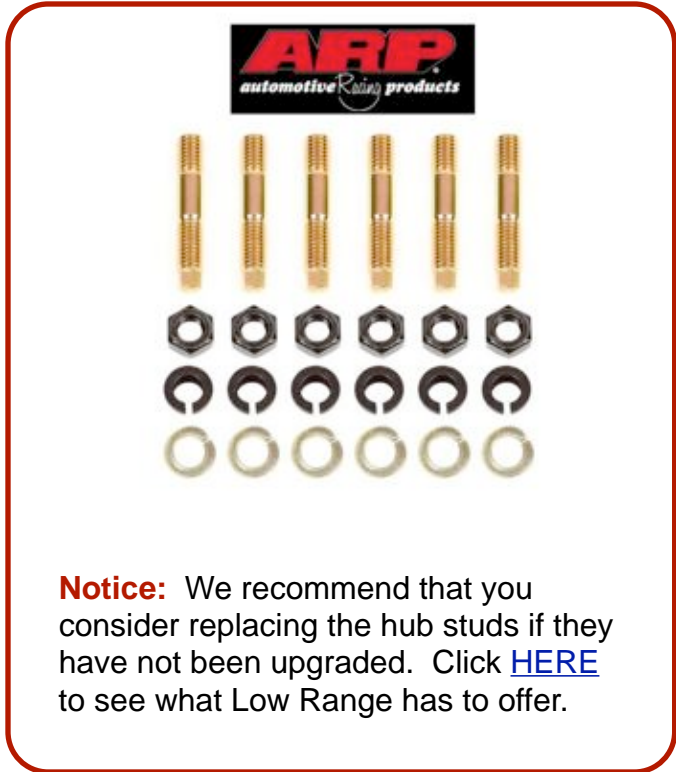

Notice: We recommend that you consider replacing the hub studs if they have not been upgraded. Click [HERE](#) to see what Low Range has to offer.



Step 35

Install the retainer bolt and washer and torque to 13 ft. lbs.

Note: Some vehicles will have a snap ring here instead of a bolt with a washer.



Step 36

Place the control handle in the "Free" position if it is not already there.





Step 37

Install a new hub cover gasket.

Note: This gasket is not considered non-reusable and should be replaced.

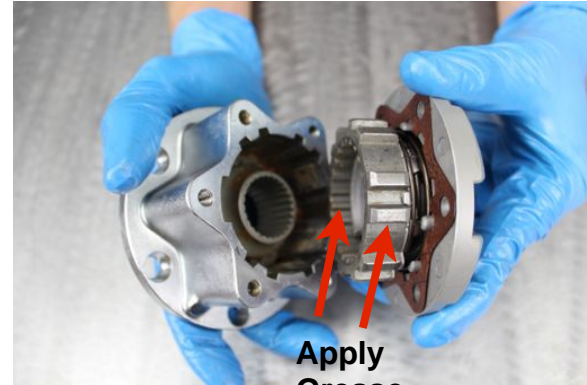

Apply Grease

Step 38

Apply some bearing grease to the inside and outside of the outer gear in the areas indicated by the arrows.

Caution: Do not FILL the hub body with grease as it will hinder operation when locking and unlocking.

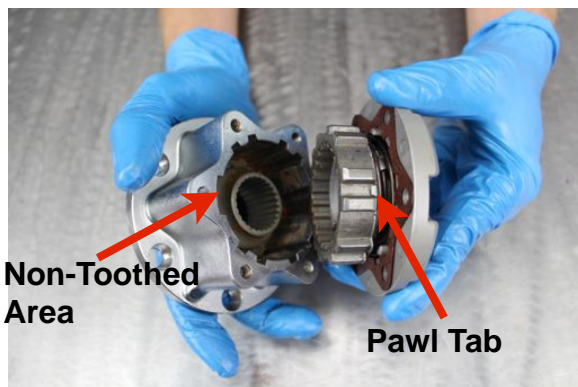

Non-Toothed Area

Pawl Tab

Step 39

Orient the follower pawl tab with a non-toothed section of the hub body and install the hub cover.

Note: Mating these parts properly may require some trial-and-error until the pins, bolt holes, teeth and gasket aligns properly. Do not force these parts together.



Step 40

Install the (6) bolt.





Step 41

Torque the bolts in a progressively tighter criss-cross pattern until 7 ft. lbs (or 84 in. lbs.) is reached. If you do not have the proper torque wrench you will need to estimate. Be careful. These threads are easily stripped.

Congratulations!!

You have successfully completed the rebuild procedures of an Aisin hub. We hope these instructions have been helpful. If you have suggestions on how to improve our instructions (or products), please email at: sales@lowrangeoffroad.com



As always, If you experience any difficulty during the installation of this product please contact Low Range Off-Road Technical Support at 801-805-6644 M-F 7:30am-5:30pm MST. Thank you for purchasing from Low Range Off-Road.



These instructions are designed as a general installation guide. Installation of many Low Range Off-Road products require specialized skills such as metal fabrication, welding and mechanical trouble shooting. If you have any questions or are unsure about how to proceed, please contact our shop at 801-805-6644 or seek help from a competent fabricator. Using fabrication tools such as welders, torches and grinders can cause serious bodily harm and death. Please operate equipment carefully and observe proper safety procedures.

Rock crawling and off-road driving are inherently dangerous activities. Some modifications will adversely affect the on-road handling characteristics of your vehicle. All products sold by Low Range Off-Road are sold for off road use only. Any other use or application is the responsibility of the purchaser and/or user. Some modifications and installation of certain aftermarket parts may under certain circumstances void your original dealer warranty. Modification of your vehicle may create dangerous conditions, which could cause roll-overs resulting in serious bodily injury or death. Buyers and users of these products hereby expressly assume all risks associated with any such modifications and use.

Revised 06/21/13© Copyright 2013 Low Range Off-Road, LC All Rights Reserved